

	Base Radius (mm)	CX	CC	Irregularity (fringes)	Clear Aperture (mm)	Surface Quality (typical)	Centration (arcmin)
R1	7.570	X		1.0	6.5	40/20	3
R2	110.31		X	1.0	6.0	40/20	

REVISIONS				
ZONE	REV.	DESCRIPTION	DATE	APPROVED

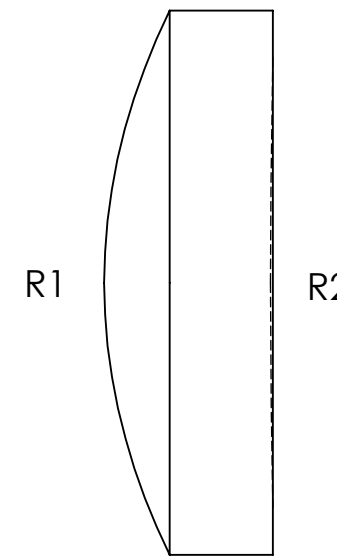
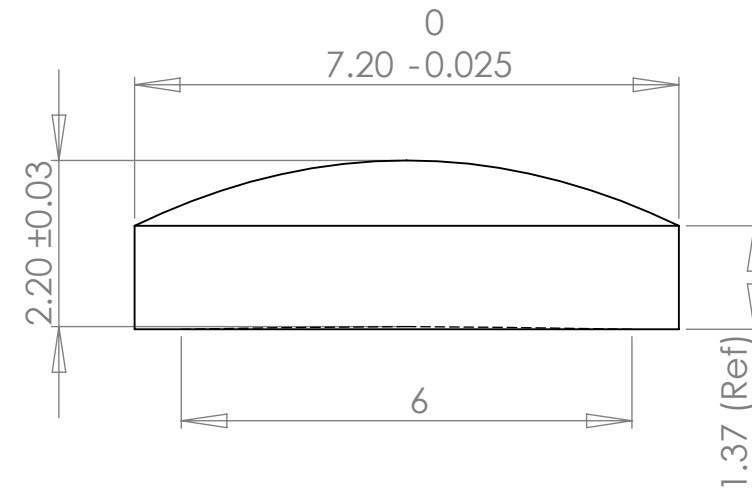
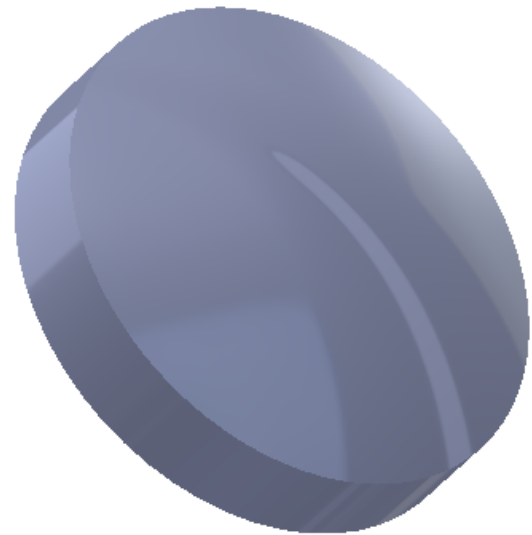

Notes:

- 1) Material: S-LAM60M (nd=1.73793, Vd=49.01)
- 2) Edge Chamfer: 0.1-0.3 mm.
- 3) AR Coating: <0.5% Reflectivity from 400-650nm ("A" coat) or 620-1080nm ("B" coat), per surface.
- 4) All dimensions in mm unless noted.

3402 Enterprise Dr.
Rowlett, TX 75088
Ph: (972) 463-8001
Web: www.archeroptx.com



PROPRIETARY AND CONFIDENTIAL
THE INFORMATION CONTAINED IN THIS DRAWING IS THE SOLE PROPERTY OF ARCHER OPTX, INC. ANY REPRODUCTION IN PART OR AS A WHOLE WITHOUT THE WRITTEN PERMISSION OF ARCHER OPTX, INC IS PROHIBITED.

UNLESS OTHERWISE SPECIFIED:		NAME	DATE	TITLE: K397
DIMENSIONS ARE IN MM		DRAWN		
TOLERANCES:		CHECKED		
FRACTIONAL ±		ENG APPR.		
ANGULAR: MACH ± BEND ±		MFG APPR.		
TWO PLACE DECIMAL ±		Q.A.		SIZE DWG. NO. REV B C2
THREE PLACE DECIMAL ±		COMMENTS:		
INTERPRET GEOMETRIC TOLERANCING PER:				SCALE: 10:1 WEIGHT: SHEET 1 OF 1
MATERIAL				
NEXT ASSY	USED ON			
FINISH				
APPLICATION		DO NOT SCALE DRAWING		